

Pilgrim Radial Fit Bolt Enquiry Form

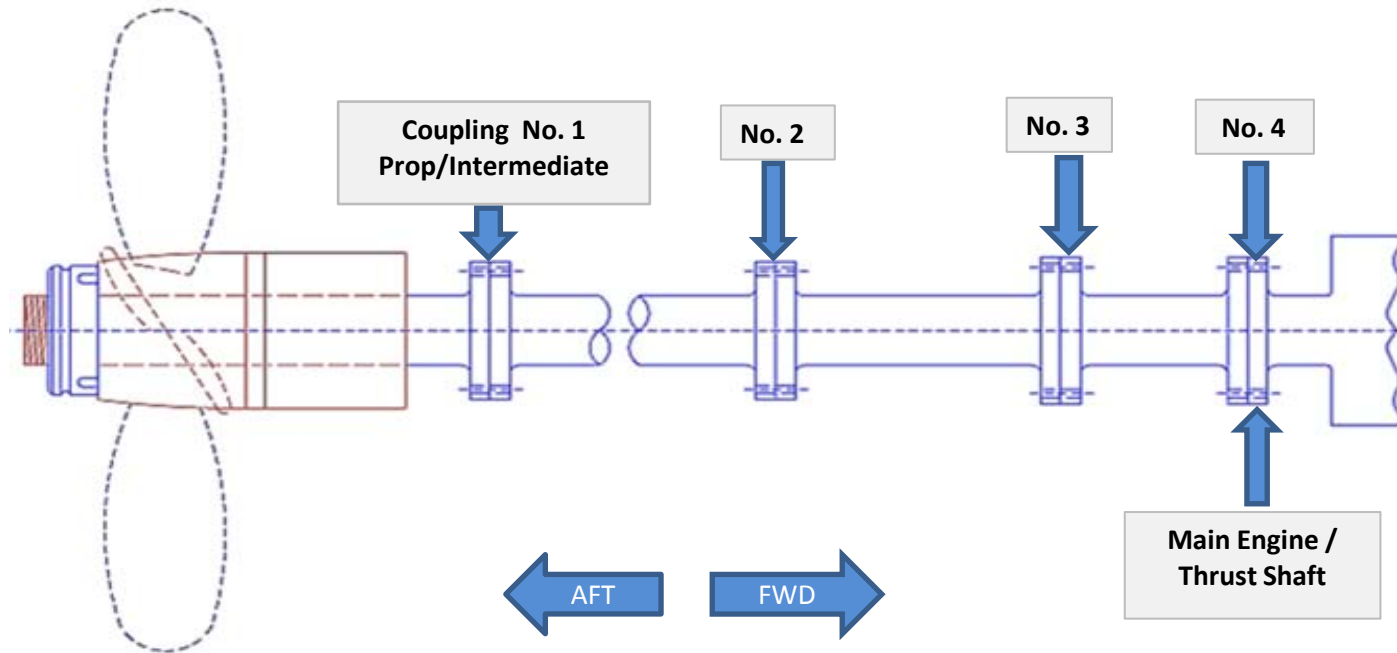

PROJECT DETAILS	
Company Name	
Ship type / size	
Project Name / Hull No.	
Class Society	
Engine Power kW	
Shaft speed RPM	
Shaft tensile Strength N/mm ²	
Shaft diameter mm	

CONTACT DETAILS	
Contact Name	
E-mail address / Telephone	

FLANGE HOLE DETAILS	No of Holes	Hole Dia.	PCD
Coupling No. 1		mm	mm
Coupling No. 2		mm	mm
Coupling No. 3		mm	mm
Coupling No. 4		mm	mm

FLANGE DETAILS	Outside dia.	FLANGE WIDTH	
		Aft	Fwd
Coupling No. 1	mm	mm	mm
Coupling No. 2	mm	mm	mm
Coupling No. 3	mm	mm	mm
Coupling No. 4	mm	mm	mm