

OPERATORS INSTRUCTION AND SAFETY MANUAL

WARNING:

THIS MANUAL IS TO BE USED IN CONJUNCTION WITH THE APPROPRIATE RADIAL FIT BOLT DATA SHEET.

1. HIGH PRESSURE HYDRAULIC EQUIPMENT CAN BE DANGEROUS IF MISUSED - KEEP AWAY FROM OIL LEAKAGES AT HIGH PRESSURE.
Jets of liquid escaping from High Pressure Equipment have sufficient power to penetrate the skin which will often cause blood poisoning. In the case of such an accident occurring, **HOWEVER SUPERFICIAL, IMMEDIATE** medical attention **MUST** be sought.
2. THIS MANUAL GIVES INSTRUCTIONS FOR OPERATING PILGRIM RADIAL FIT BOLTS. OBSERVANCE OF THE PROCEDURES COVERED IN THIS PUBLICATION IS ESSENTIAL FOR THE SAFETY OF PERSONS WHO USE AND MAINTAIN THE EQUIPMENT AND WORKING AREAS WHERE THE EQUIPMENT IS LIKELY TO BE USED OR MAINTAINED.

IT IS ESSENTIAL THAT ALL PERSONS INVOLVED WITH EQUIPMENT COVERED BY THIS MANUAL SHOULD READ THE SAFETY NOTES IN SECTION 7.

IF IN DOUBT, CONSULT: **Pilgrim** International Ltd.

**PILGRIM RADIAL FIT BOLTS
WITH EXTERNAL THREAD**



Pressure vessels supplied as part of the Radial Fit Bolt Tensioning Kit comply with the requirements of the Pressure Equipment Directive 97/23/EC Category 1 Module A and are CE marked accordingly.

CONTENTS

SECTION 1	INTRODUCTION
SECTION 2	HOLE PREPARATION
SECTION 3	INSTALLATION PROCEDURE
SECTION 4	DISMANTLING PROCEDURE
SECTION 5	HYDRAULIC PUMP AND HARNESS
SECTION 6	RECOGNISING FAULTS AND PARTS REPLACEMENT
SECTION 7	SAFETY NOTES



**PILGRIM RADIAL FIT BOLTS
WITH EXTERNAL THREAD**

INTENTIONALLY BLANK

**PILGRIM RADIAL FIT BOLTS
WITH EXTERNAL THREAD**

SECTION 1

1.1. INTRODUCTION

This manual is intended to give a step-by-step guide to the installation and removal of PILGRIM Radial Fit Bolts, PILGRIM Clamp Bolts and also covers the safe use of all associated hydraulic equipment during these operations.

A data sheet is provided to accompany this manual with specific details of your application.

This manual should be read in conjunction with the Arrangement Drawings stated on the Data Sheet. The Arrangement Drawings have been prepared to cover the exact details of the particular application, unlike the diagrams within this Manual which illustrate a typical application only.

1.2 CONSTRUCTION AND USE

The PILGRIM Radial Fit Bolt is a cost effective fitted bolting system designed to simplify installation and removal. It works on the principle of pulling a taper shank bolt into a matching taper bored sleeve expanding its outside diameter to exert a radial force in the hole, creating a controlled interference fit.

The Bolt is installed and removed in the clearance condition, which overcomes problems such as bolt seizure and hole damage which are common-place with conventional fitted bolts and ensures that the Bolts are re-usable. The Bolts have been designed to give easy and accurate alignment and, combined with the simplified fitting and removal procedures, offer benefits in time and cost savings.

In a typical example, in order to produce a cost effective solution to propulsion shaft flange bolting problems, the PILGRIM Radial Fit Bolt can be used in combination with PILGRIM Clamp Bolts which are fitted in a clearance condition and provide an axial clamping force only on the shaft flanges. The full diameter of the PILGRIM Radial Fit Bolt (Sleeve plus Bolt) is effective in transmitting torque by shear force in the bolts. The total axial clamping force on the flange, which is effective in transmitting thrust and bending loads and also in maintaining the flange alignment, is the addition of the clamping force in the Radial Fit Bolts and the Clamp Bolts.

The constructional details together with brief details of the Installation and Removal procedure are illustrated overleaf.

**PILGRIM RADIAL FIT BOLTS
WITH EXTERNAL THREAD**

SECTION 2 HOLE PREPARATION

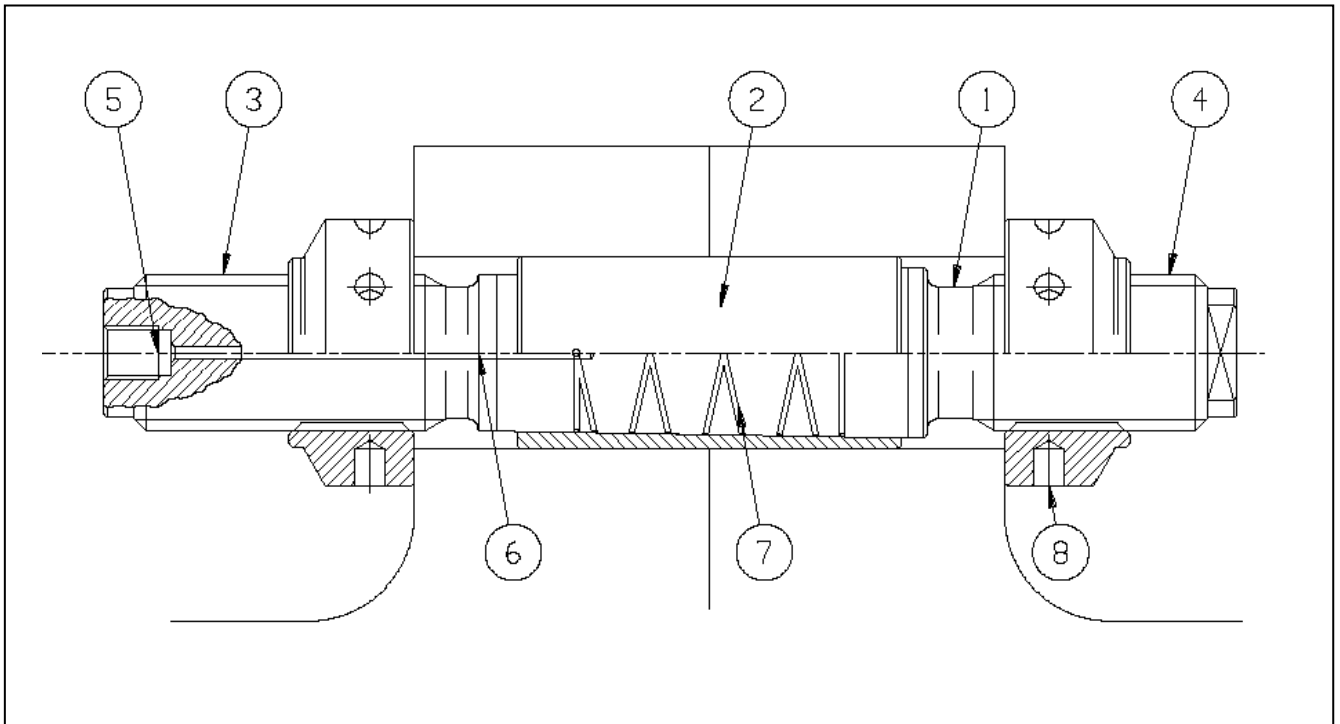

KEY

- 1. Radial Fit Bolt with tapered shank
- 2. Taper bored sleeve
- 3. Extra long external thread
- 4. External thread
- 5. Internal thread for oil injection adapter
- 6. Internal oilway
- 7. Oil distribution grooves
- 8. Round nut with tommy bar holes

ANCILLARY EQUIPMENT (not shown)

- Hydraulic Head
- Tensioning Bridge
- Setting bridge
- Puller
- Oil Injection Adapter
- Hydraulic Pump
- Hydraulic Link Pipe

INSTALLATION PROCEDURE

Assemble the taper bored sleeve onto the tapered shank bolt and insert the assembly into the coupling flange hole in the clearance condition. Using a hydraulic head to locate and position the tapered sleeve, the bolt is pulled through the sleeve which expands to achieve a radial fit in the hole. The nuts are then hand tightened and the same equipment is used to develop a clamping force on the flanges.

REMOVAL PROCEDURE

The bolt is initially detensioned and the nuts loosened but not removed. Oil is then injected between the mating surfaces of the bolt and the sleeve via the internal oilway and distribution grooves to eject the bolt from the sleeve. The nuts are removed and the assembly withdrawn from the coupling hole in the clearance condition.

**PILGRIM RADIAL FIT BOLTS
WITH EXTERNAL THREAD**

SECTION 2 HOLE PREPARATION

2.1 INTRODUCTION

2.1.1 The Sleeves for Radial Fit Bolts are normally supplied 2.5mm (0.1") oversize on nominal diameter to allow for their machining by customer to suit final, measured, bored hole sizes.

At special request sleeves can be supplied finish machined to size with the correct fitting allowance to suit:-

- a) hole sizes supplied by customer
- or b) holes bored by customer to H7 tolerances shown in the following table:-

Nominal Hole/ Sleeve dia.	30 - 50mm (1.2-2.0")	50 - 80mm (2.0-3.15")	80 - 120mm (3.15-4.75")	120 – 180mm (4.75-7.09")
Tolerance (H7)	0.025mm (0.001")	0.03mm (0.0012")	0.035mm (0.0014")	0.04mm (0.0016")

2.1.2 Where PILGRIM Radial Fit Bolts are to be fitted as a replacement for conventional fitted bolts, removal of the fitted bolt may result in damage to the machined surface of the hole or the bolt having to be bored out where it has become seized during withdrawal. In either case, where the PILGRIM Radial Fit Bolt is to be installed, the bolt holes have to be line bored and/or honed in exactly the same way as for conventional bolts. Steps in the bore at the interface between coupling halves must be avoided.

**2.2. MACHINING SPECIFICATION FOR
BOLT HOLES AND SLEEVES**

2.2.1 The surface of the holes must be smooth and free from score marks. Surface finish must not exceed 1.6 micrometers (63 microinches). The diameter must be circular, straight and parallel within the Form Tolerance stated in the table below:-

Nominal Hole/ Sleeve dia.	30 - 50mm (1.2-2.0")	50 - 80mm (2.0-3.15")	80 - 120mm (3.15-4.75")	120 – 180mm (4.75-7.09")
Form Tolerance	0.013mm (0.0005")	0.015mm (0.0006")	0.018mm (0.0007")	0.02mm (0.0008)

The hole diameter should be measured at 4 or 5 positions along the fitted length. Measure two diameters 90 deg. apart at each position. All measurements should be recorded and the minimum diameter taken as final hole diameter.

After boring, the holes must be identified, measured and the sizes recorded in accordance with machine manufacturer's recommendations.

**PILGRIM RADIAL FIT BOLTS
WITH EXTERNAL THREAD****SECTION 2 HOLE PREPARATION (cont'd)**

- 2.2.2 Where the sleeves are supplied finished machined, the sleeves will have been machined to give the correct clearance for fitting into the hole sizes given by the customer or to suit H7 Tolerance holes. The clearance allowance is stated in the Data Sheet.
- 2.2.3 Where the sleeves are supplied oversize for machining by customer to suit measured hole sizes recorded in 2.2.1, the outside diameter has to be machined by grinding or fine turning to the measured hole size minus the clearance allowance stated in on the Data Sheet. The sleeve should be circular, straight and parallel within the tolerance stated in the Table in Section 2.2.1. The surface finish must not exceed 1.6 micrometers (63 microinches). To prevent distortion of the sleeve during machining due to its thin wall, the sleeve should be mounted on the mandrel, having a matching taper, supplied with the sleeves. (See FIG 2.2.3)

It is recommended to aim for the maximum clearance stated when machining the sleeve.

**2.3. BORING PROCEDURE:**

- 2.3.1 The in-situ boring of flange holes is normally carried out after the shafts have been lined up and flanges pulled together by slave or temporary bolts. A minimum of four temporary bolts are recommended. The lining up, parallelism and concentricity checks should be carried out in accordance with machine or shaft manufacturer's instructions.
- 2.3.2 Two holes above the shaft centre line and approximately 90 deg. apart should be bored through, measured and the Radial Fit Bolts installed using the procedure detailed in Section 3 of this Manual. The shaft should be turned through 180 deg. and two further bolt holes bored, measured and Bolts installed. The shaft should be turned through 90 deg. and the process of boring and installing the Radial Fit Bolts repeated until all Bolts are fitted. The temporary bolts should be removed one by one during this process.
- 2.3.3 Where PILGRIM Clamp (Clearance) Bolts are fitted the body of the Bolt should have a small clearance in the hole in accordance with machine manufacturer's recommendations in order to centralise the Bolt. It is important in high speed applications to maintain coupling balance.
- 2.3.4 The end faces of the flanges under the Nuts should have a surface finish not exceeding 3.2 micrometers (125 microinches) and be square to bore within 0.2mm (.008") Total Indicator Reading.

NOTE: The flange hole diameters must never be smaller than the machine manufacturer's original nominal diameter. This situation may occur after the flange holes have been bushed.

**PILGRIM RADIAL FIT BOLTS
WITH EXTERNAL THREAD**

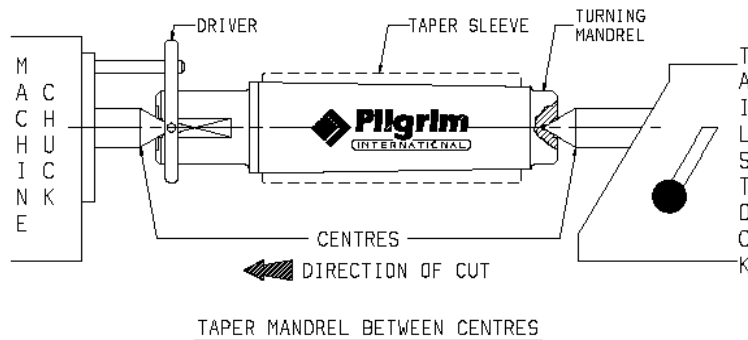
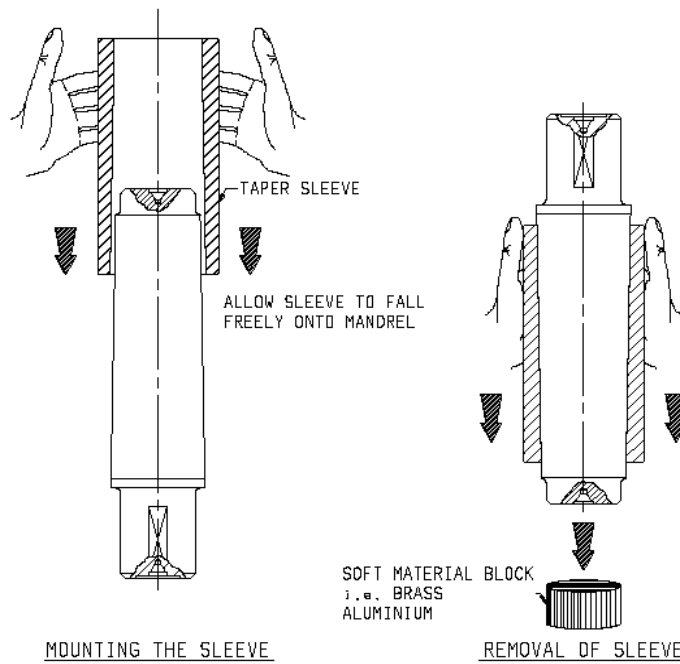
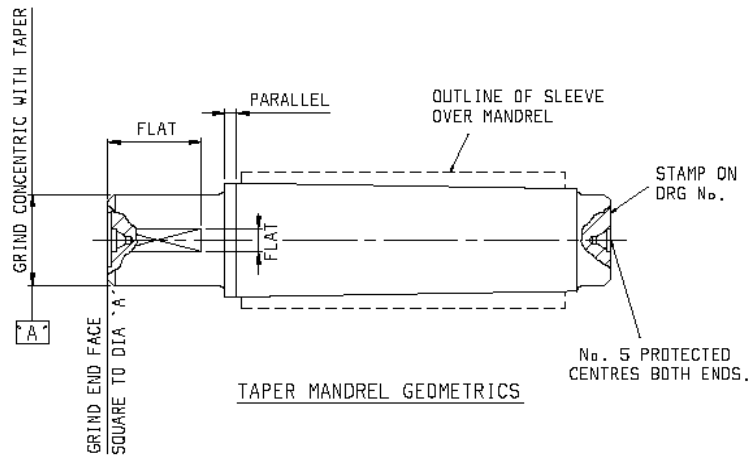

FIG. 2.2.3

**PILGRIM RADIAL FIT BOLTS
WITH EXTERNAL THREAD**

SECTION 3 INSTALLATION PROCEDURE

3.1. PREPARATION

3.1.2. BOLT TENSIONING KIT

3.1.2.a A Storage Box is provided for all parts of the Bolt Tensioning Kit.

3.1.2.b Check that all parts of the Bolt Tensioning Kit are available. See copy of Assembly Drawing included with this Manual for list of parts required and identification - see Data Sheet for drawing number.

- Spare seals should always be available for the Hydraulic Heads prior to use of the Bolt Tensioning kit.

3.1.2.c Clean all parts and examine for any apparent defects or damage which may have occurred since last used. If any serious defects are present refer to **Pilgrim International Ltd** for advice before attempting use.

3.1.2.d TECHNICAL DATA - BOLT TENSIONING KIT

Maximum Working Pressure (Design Pressure) given in Data Sheet is the maximum system pressure and not necessarily the Operating Pressure.

Use the **OPERATING PRESSURES** stated in Data Sheet for setting of Sleeves and tensioning the Bolts.

NOTE:

After use, all parts of the Bolt Tensioning Kit should be coated with rust preventative and returned to the Storage Box. Stow the Storage Box in a secure, dry location for future use.

**PILGRIM RADIAL FIT BOLTS
WITH EXTERNAL THREAD**

SECTION 3 INSTALLATION PROCEDURE (cont'd)

3.1. PREPARATION (cont'd)

3.1.3. RADIAL FIT BOLTS AND NUTS

3.1.3.a Clean off protective coating from Bolts, Taper Sleeves and Nuts. (See Assembly Drawing included with this Manual for identification - the drawing number is quoted on the Data Sheet).

PLEASE NOTE: Bolts, Sleeves and Nuts are shipped assembled as a unit and marked with corresponding numbers. Although components are interchangeable it is recommended this grouping should be maintained after cleaning and installation. This may be important to maintain weight tolerance of Bolts for balance purposes or where sleeves have been finished machined prior to delivery.

3.1.3.b The tapered surfaces of the Bolts and the bore of the Sleeves should be cleaned and degreased with Silkolene or similar evaporating solvent.

NOTE: Radial Fit Bolt Sleeves are designed to be assembled **DRY** - **DO NOT** lubricate the tapered surfaces on the bolt or sleeve in any way.



3.1.3.c Assemble the Sleeve onto the Bolt by holding the Bolt vertically with the small end of the taper uppermost. Hold the Sleeve with its end face level with the top of the tapered section of the Bolt and allow the Sleeve to fall, under its own weight, onto the Bolt. Check that the Sleeve is locked onto the Bolt by applying hand force only to the Sleeve.

DO NOT APPLY ADDITIONAL FORCE TO THE SLEEVE SUCH AS TAPPING WITH A HAMMER OR MALLET.

3.1.4 CLAMP BOLTS AND NUTS (IF SUPPLIED)

3.1.4.a Clean off protective coating from Bolts and Nuts. (See Assembly Drawing included with this Manual for identification - the drawing number is quoted on the Data Sheet).

NOTE: Maintain grouping of coupling of Bolts and Nuts as stated in Section 3.1.3.a.

SECTION 3 INSTALLATION PROCEDURE (cont'd)

3.2 INSTALLATION OF PILGRIM RADIAL FIT BOLTS (cont'd)

IMPORTANT NOTES

A) LOAD RING RETRACTION

When fitting or removing the Hydraulic Head during the Installation and Dismantling Procedures that follow, it is IMPORTANT that the Load Ring in the Hydraulic head is **fully retracted**.

To retract the Load Ring, the Hydraulic Head should be screwed onto the Bolt with the Hydraulic Hose connected and the pressure release valve on the pump 'open'. The Load Ring should be in contact with the Setting or Tensioning Bridge.

Turn the Hydraulic Head clockwise using the tommy bar supplied until the Load Ring is fully retracted. This **cannot** be done with the Hydraulic Hose **disconnected** as the non-return valve in the Quick Connect nipple will be closed. The Load Ring should always be retracted **before** removing the Hydraulic Head at any stage during the following procedures.

B) PUMP OPERATION

When releasing hydraulic pressure, always open the Release Valve on the Pump **slowly** to avoid damage to the system.

**PILGRIM RADIAL FIT BOLTS
WITH EXTERNAL THREAD****SECTION 3 INSTALLATION PROCEDURE** (cont'd)**3.2 INSTALLATION OF PILGRIM RADIAL FIT BOLTS** (cont'd)**RADIAL LOADING**

- 3.2.1 Insert the Radial Fit Bolt, with Tapered Sleeve fitted, into the pre-bored hole in the flange. The Sleeve diameter is smaller than the hole so that the Bolt can be easily slid into position by hand. (See FIG. 3.2.1)

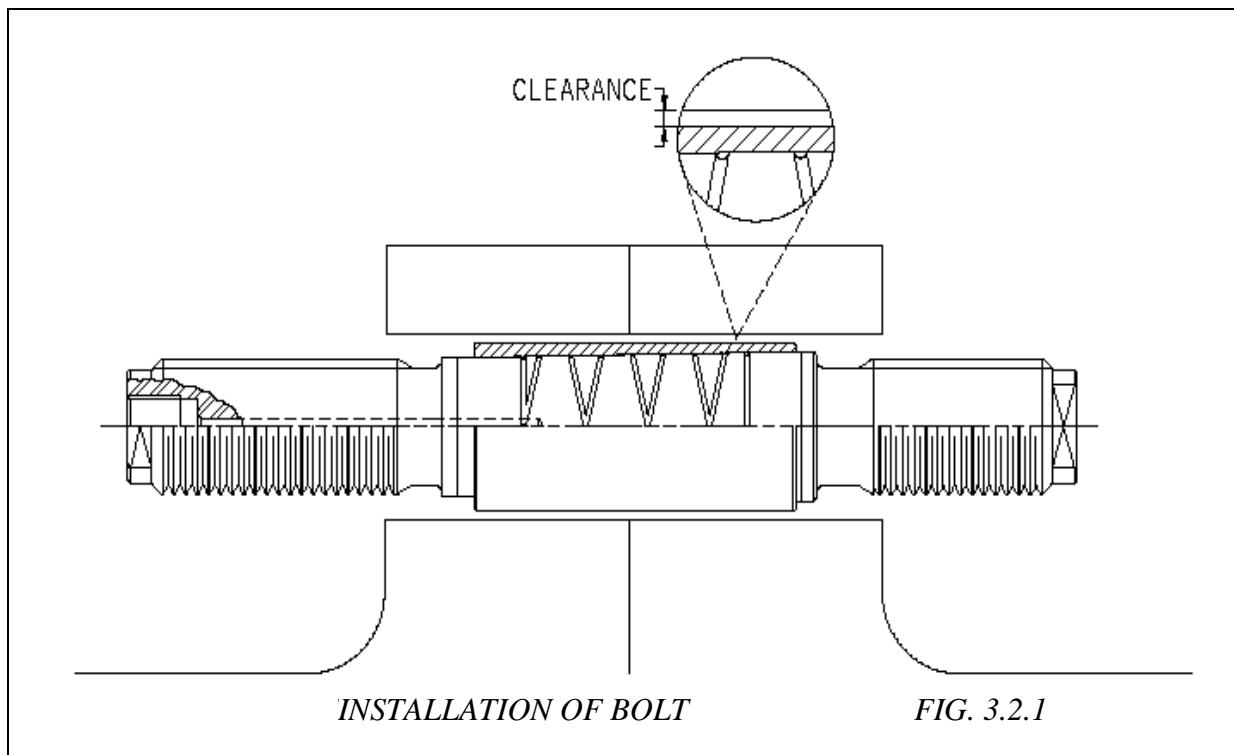

To ensure that the Taper Sleeve is correctly positioned with respect to the split line of the coupling - it is **IMPORTANT** to insert the Radial Fit Bolt in the correct direction.

**PILGRIM RADIAL FIT BOLTS
WITH EXTERNAL THREAD**

SECTION 3 INSTALLATION PROCEDURE (cont'd)

3.2 INSTALLATION OF PILGRIM RADIAL FIT BOLTS (cont'd)

3.2.2 Position the Bolt assembly and insert the Setting Bridge into the hole, at the long thread end of the Bolt, to locate against the Sleeve.

- Ensure that faces 'A' and 'B' are in contact

(See FIG. 3.2.2)

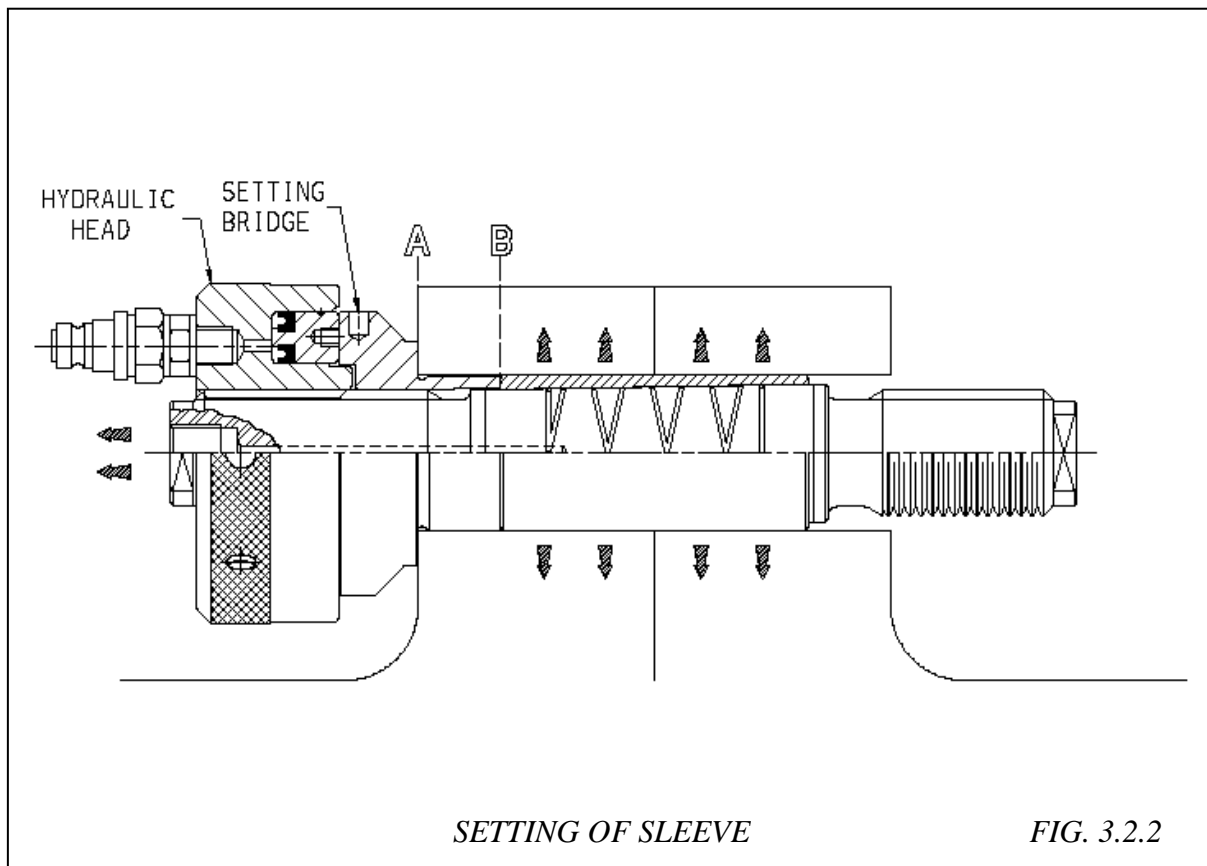

**PILGRIM RADIAL FIT BOLTS
WITH EXTERNAL THREAD**

SECTION 3 INSTALLATION PROCEDURE (cont'd)

3.2 INSTALLATION OF PILGRIM RADIAL FIT BOLTS (cont'd)

3.2.3 Screw the Hydraulic Head onto the Bolt until it is nipped tight against the Setting Bridge.

3.2.4 Apply the Sleeve Setting Pressure (see Data Sheet) to the Hydraulic Head to pull the Bolt into the Tapered Sleeve. This expands the sleeve to take up clearance and creates a controlled interference fit.

- See FIG. 3.2.2 and Data Sheet. For location and identification of parts see Bolt Tensioning Kit Assembly drawing, Section A, Sheet 1. (See Data Sheet).

3.2.5 Release the hydraulic pressure.

- Because the tapers in the Sleeve and on the Bolt are self-locking, the interference fit will be maintained when the hydraulic pressure is released.

3.2.6 Remove the Hydraulic Head and Setting Bridge.

AXIAL LOADING

3.2.7 Fit the Round Nuts to each end of the Bolt and hand-tighten.

- Maintain grouping of Bolts with individual nuts

Fit the Tensioning Bridge, followed by the Hydraulic Head, at the long thread end of the Bolt.

IMPORTANT

WHERE THE TENSIONING BRIDGE HAS MACHINED SURFACE TO AVOID CONTACT WITH THE SHAFT RADIUS ENSURE THAT THE BRIDGE IS CORRECTLY POSITIONED TO LINE UP THE CHAMFER & RADIUS. See fig 3.2.3

**PILGRIM RADIAL FIT BOLTS
WITH EXTERNAL THREAD**

SECTION 3 INSTALLATION PROCEDURE (cont'd)

3.2 INSTALLATION OF PILGRIM RADIAL FIT BOLTS (cont'd)

3.2.8 Apply the Bolt Tensioning Pressure (see Data Sheet) to the Hydraulic Head. This stretches the Bolt allowing the Round Nut to be tightened against the flange face by turning the Nut itself using the tommy bar supplied.

3.2.9 Release the hydraulic pressure; the Bolt will retain the axial clamp load.

- See Data Sheet - For location and identification of parts see Bolt Tensioning Kit Assembly Drawing, Section B, Sheet 1. (See Data Sheet).

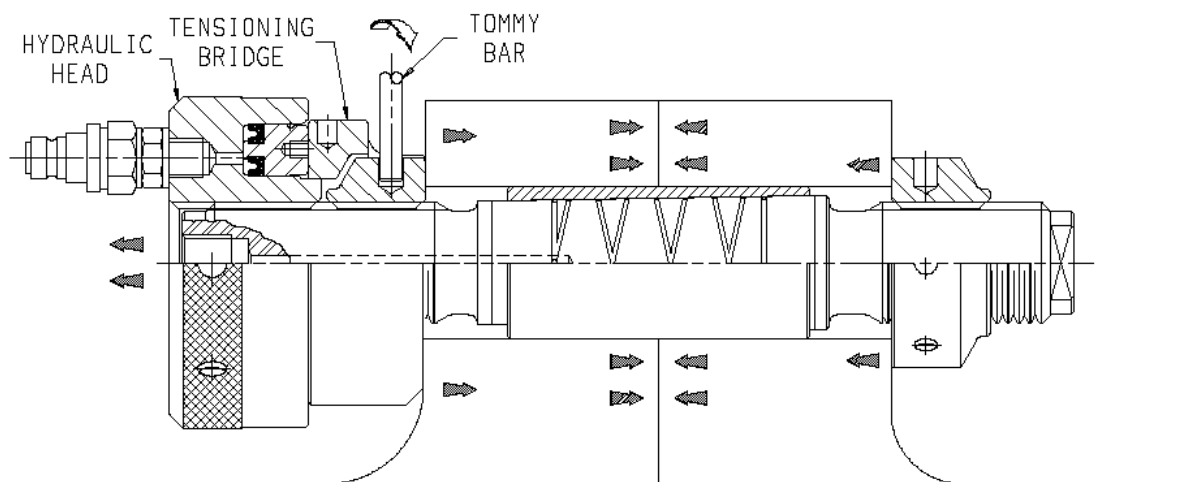

TENSIONING OF BOLT

FIG. 3.2.3

3.2.10 Re-apply the Bolt Tensioning Pressure as in 3.2.8 and re-tighten the Nut against the flange face.

- This is important as it will ensure that the maximum load is retained in the Bolt.

3.2.11 Release the hydraulic pressure.

**PILGRIM RADIAL FIT BOLTS
WITH EXTERNAL THREAD**

SECTION 3 INSTALLATION PROCEDURE (cont'd)

3.2 INSTALLATION OF PILGRIM RADIAL FIT BOLTS (cont'd)

- 3.2.12 Remove the Hydraulic Head, Tensioning Bridge. Fit the thread protectors (when supplied) over the extended threads at each end of the Bolt.

The Radial Fit bolt is now installed and tensioned.

PROCEDURE STEPS 3.2.1 to 3.2.12 ARE REPEATED FOR EACH RADIAL FIT BOLT IN THE FLANGE.

It is a good idea to mark the Bolt or Coupling after each Bolt Sleeve is expanded and each Bolt is tensioned. This will help to avoid any stage of the installation being missed.



3.2.13 IMPORTANT NOTE

It is well recognised that when loading a series of bolts individually or in pairs the bolts which are loaded earlier in the series can lose some of their original load as the subsequent bolts are loaded. This loss is caused by movement and compression in the whole assembly as the combined bolt load increases. It is therefore necessary to repeat the tensioning operation for all the bolts for a second time to guarantee a maximum and uniform load throughout all the bolts.

**PILGRIM RADIAL FIT BOLTS
WITH EXTERNAL THREAD**

SECTION 3 INSTALLATION PROCEDURE (cont'd)

3.3 INSTALLATION OF PILGRIM CLAMP BOLTS (IF SUPPLIED)

3.3.1 Insert the Clamp Bolt into the hole in the flange and fit Round Nuts at each end. Ensure that the Bolt is inserted in the correct direction as shown on Assembly Drawing (see Data Sheet for Assembly Drawing Number).

- Maintain grouping of Nuts with individual bolts.

3.3.2 Adjust the position of the Round Nuts so that the Bolt projects the correct amount at on each side of the coupling, as shown on Assembly drawing referred to in the Data Sheet. See also FIG. 3.3.1

3.3.3 Fit the Tensioning Bridge, followed by the Hydraulic Head, at the long thread end of the Bolt. Apply the Bolt Tensioning Pressure (see Data Sheet).

This stretches the Bolt allowing the Round Nut to be tightened against the flange face by turning the Nut using the tommy bar supplied.

3.3.4 Release the hydraulic pressure, retaining an axial clamp load in the Bolt. (See FIG. 3.3.1. For location and identification of parts see Bolt Tensioning Kit Assembly Drawing Section B, Sheet 1. See Data Sheet, - for Drawing Number).

**PILGRIM RADIAL FIT BOLTS
WITH EXTERNAL THREAD**

SECTION 3 INSTALLATION PROCEDURE (cont'd)

3.3 INSTALLATION OF PILGRIM CLAMP BOLTS (IF SUPPLIED) (cont'd)

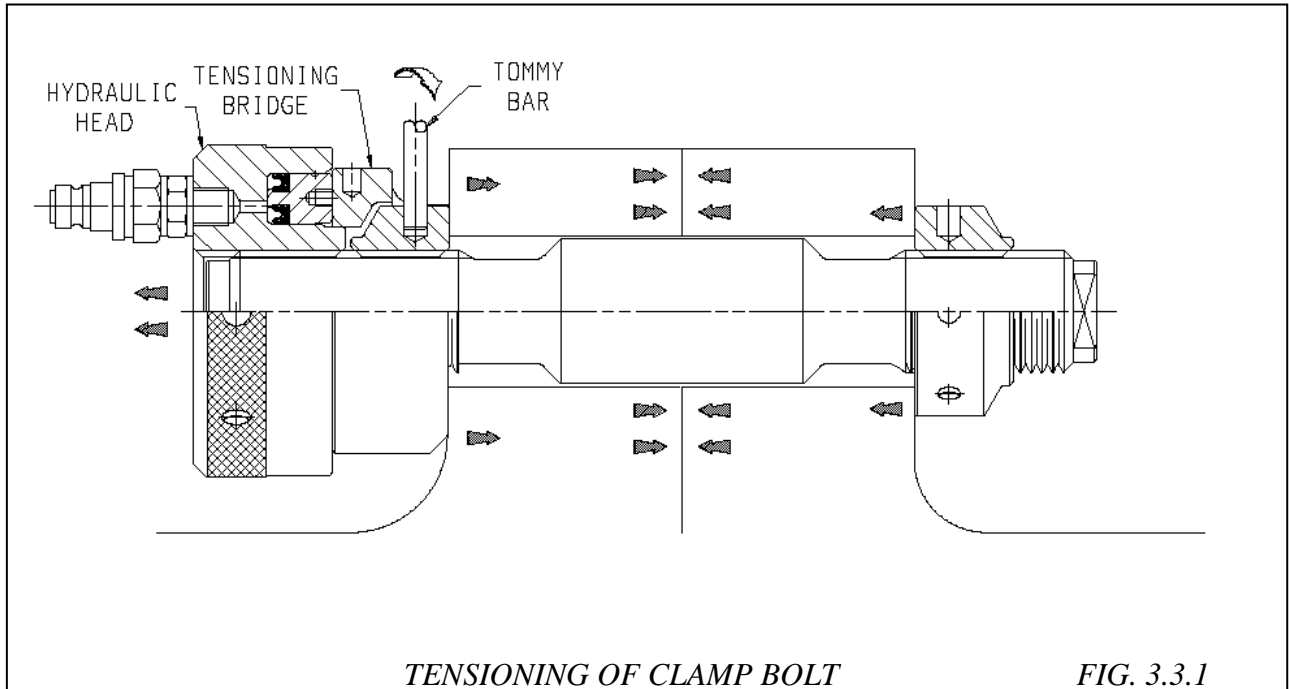

3.3.5 Re-apply the Bolt Tensioning Pressure as in 3.3.4 and re-tighten the Nut against the flange face. This is important as it will ensure that the maximum load is retained in the Bolt. Release the hydraulic pressure.

3.3.6 Remove the Hydraulic Head and Tensioning Bridge, and fit thread protectors (when supplied) over the extended thread. The Clamp Bolt is now installed and tensioned.

PROCEDURE STEPS 3.3.1 to 3.3.6 ARE REPEATED FOR EACH CLAMP BOLT IN THE FLANGE.

It is a good idea to mark the Bolt or Coupling after each Bolt Sleeve is expanded and each Bolt is tensioned. This will help to avoid any stage of the installation being missed.



3.3.7 IMPORTANT NOTE

It is well recognised that when loading a series of bolts individually or in pairs the bolts which are loaded earlier in the series can lose some of their original load as the subsequent bolts are loaded. This loss is caused by movement and compression in the whole assembly as the combined bolt load increases. It is therefore necessary to repeat the tensioning operation for all the bolts for a second time to guarantee a maximum and uniform load throughout all the bolts.

**PILGRIM RADIAL FIT BOLTS
WITH EXTERNAL THREAD**

SECTION 4 DISMANTLING PROCEDURE

4.1 REMOVAL OF PILGRIM RADIAL FIT BOLTS

4.1.1 Remove the Thread Protectors from each end of the Bolt. Fit the Tensioning Bridge and Hydraulic Head at the long thread end of the Bolt. A pressure similar to the Tensioning Pressure (see Data Sheet) is applied until the Round Nut becomes loose - back-off the Round Nut two turns.

DO NOT REMOVE NUT FROM BOLT.

See FIG. 4.1.1

During the de-tensioning stage the Hydraulic Head should be backed off from the Tensioning Bridge by quarter of a turn before pressurisation to avoid locking up as the bolt retracts to its original length.



WARNING:

IF THE NUTS ARE REMOVED DURING THE OIL INJECTION PROCESS, THE BOLT CAN BE EJECTED FROM THE HOLE WITH ENOUGH VELOCITY TO CAUSE INJURY OR DAMAGE.

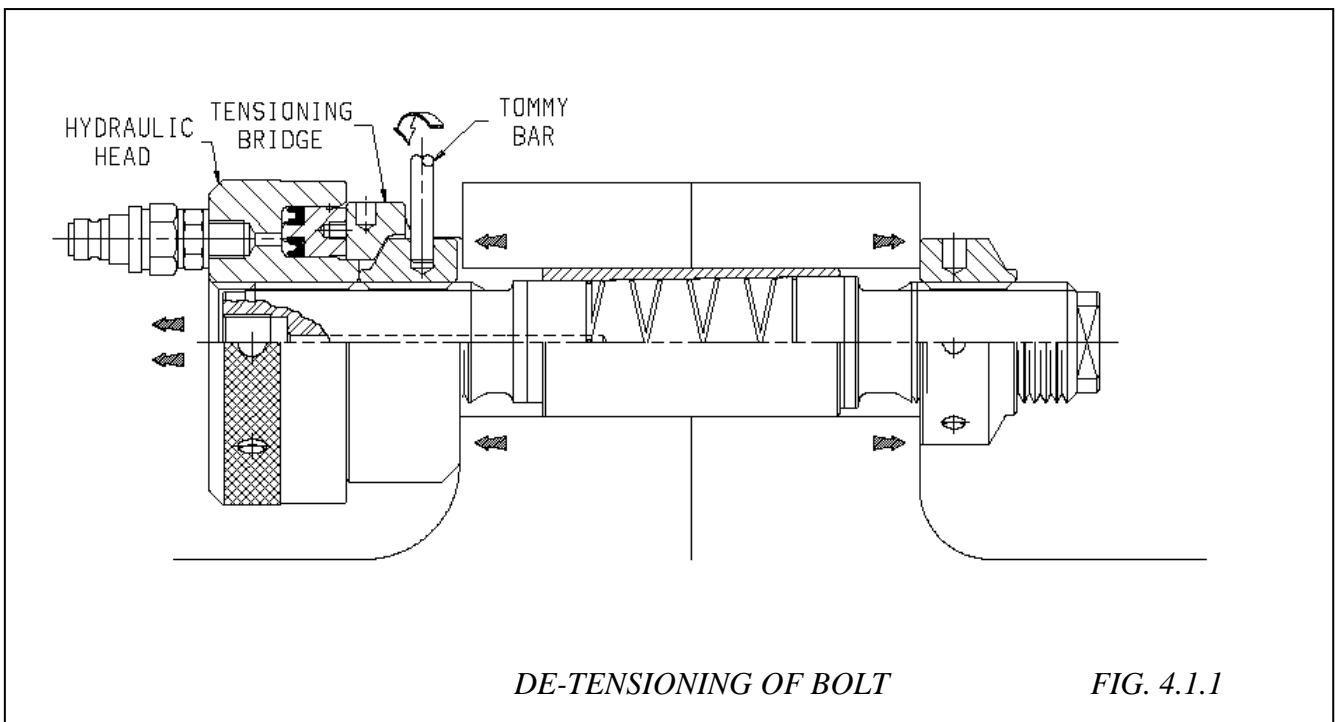

4.1.2 Remove Hydraulic Head and Tensioning Bridge. See FIG. 4.1.1 and Data Sheet. For location and identification of parts see Bolt Tensioning Kit Assembly Drawing - Section B.

**PILGRIM RADIAL FIT BOLTS
WITH EXTERNAL THREAD**

SECTION 4 DISMANTLING PROCEDURE

4.1 REMOVAL OF PILGRIM RADIAL FIT BOLTS (cont'd)

4.1.3 The oil injection adaptor is connected to the small internal thread in the Bolt and pressure applied via internal oil ports to the interface between the Bolt and Tapered Sleeve. As the pressure increases the sleeve releases from the taper on the Bolt and reduces in diameter, thus relieving the interference fit. The pressure required to release the Sleeve is stated on the Data Sheet. **DO NOT** exceed the maximum pressure stated.

NOTE: It is important that the correct grade of oil is used for this operation to avoid leakage - see Section 5.1.1.



See FIG. 4.1.3 and Data Sheet. For location and identification of parts see Bolt Tensioning Kit Assembly Drawing - Section C.

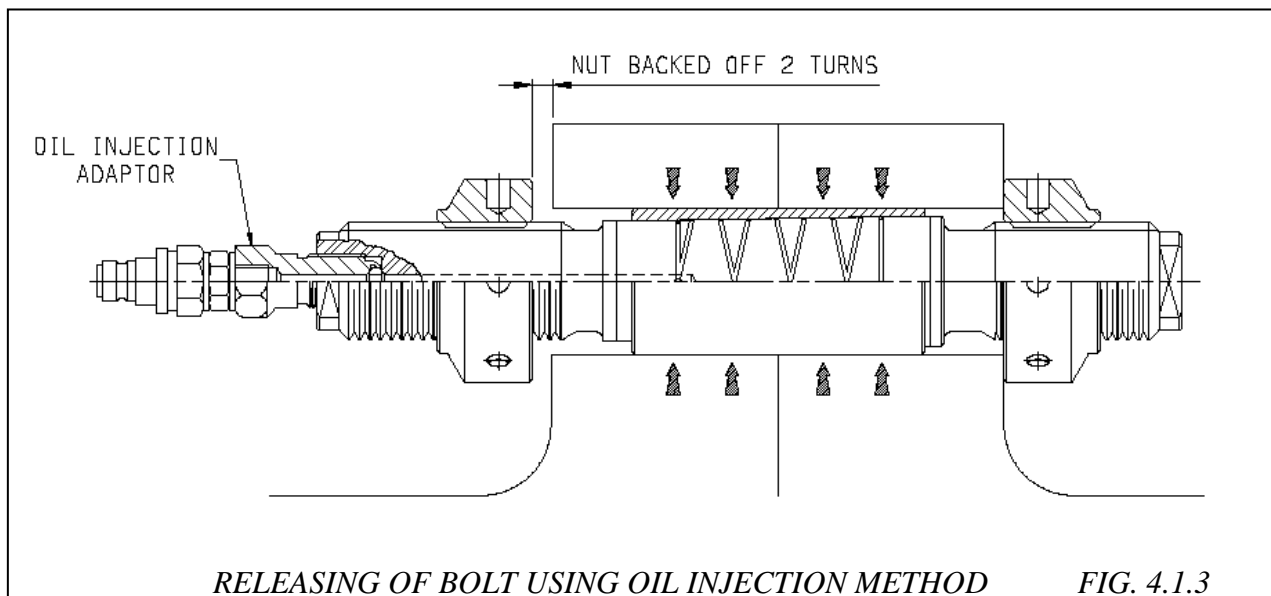

**PILGRIM RADIAL FIT BOLTS
WITH EXTERNAL THREAD**
SECTION 4 DISMANTLING PROCEDURE
4.1 REMOVAL OF PILGRIM RADIAL FIT BOLTS

(cont'd)

- 4.1.4 If the Sleeve will not release at the maximum Sleeve Release Pressure stated in the data Sheet, the following alternative procedure should be used.
- 4.1.5 Remove the Nut at the short thread end of the Bolt using procedure in Section 4.1.1. Only apply pressure to the Hydraulic Head until the Nut becomes loose.
- the pressure required should not be more than 350 bar (5075 psi).
- 4.1.6 Fit the Removal Bridge and Hydraulic Head at the end opposite to oil injection adapter. Apply pressure to the Hydraulic Head to pull the Bolt out of Sleeve which will reduce in diameter allowing the Bolt and Sleeve to be removed from the hole. A pressure approximately equal to the Sleeve Setting Pressure will be required. SEE FIG. 4.1.6

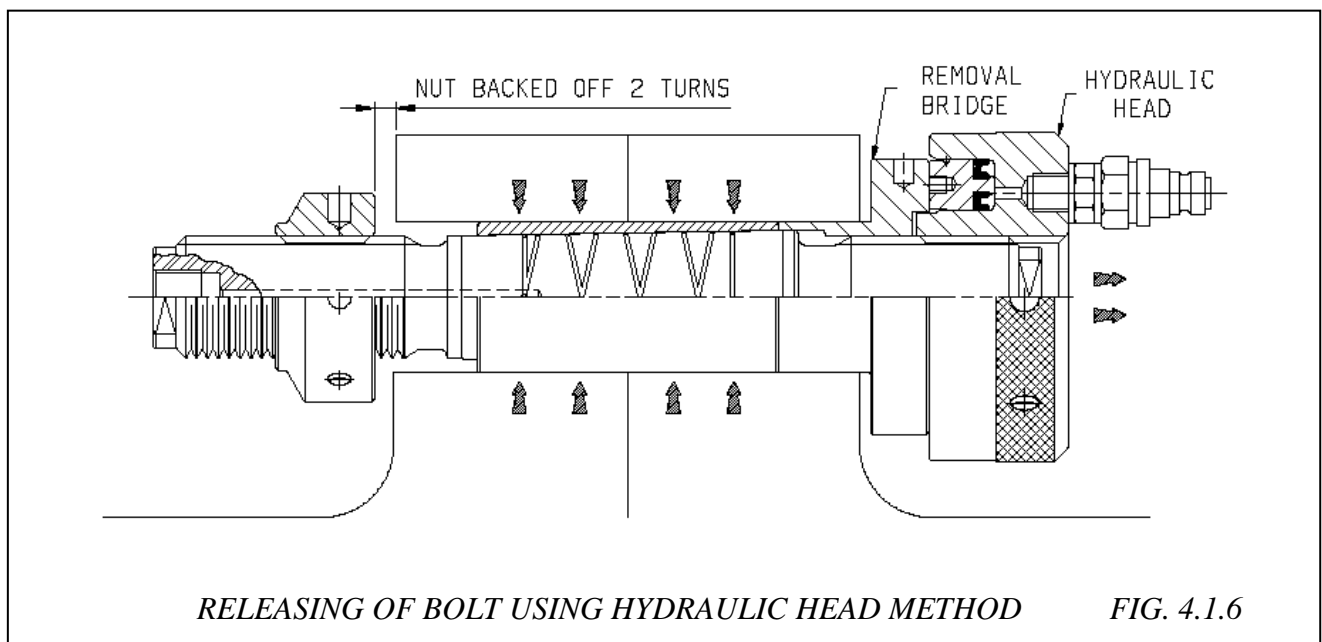

- 4.1.7 The Round Nut at the oil injection end can now be removed and the Radial Fit Bolt and Sleeve withdrawn from the flange.

NOTE: To preserve coupling balance, when dismantling be sure to re-assemble the Bolt, Sleeve and Nuts associated with each bolt hole as a group.

PROCEDURE STEPS 4.1.1 to 4.1.7 ARE REPEATED FOR EACH BOLT IN THE FLANGE

**PILGRIM RADIAL FIT BOLTS
WITH EXTERNAL THREAD**

SECTION 4 DISMANTLING PROCEDURE (cont'd)

4.2 DISMANTLING OF PILGRIM CLAMP BOLTS

4.2.1 Remove the Thread Protectors from each end of the Bolt. Fit the Tensioning Bridge and the Hydraulic Head at the long thread end of the Bolt. A pressure similar to the Tensioning Pressure - (see Data Sheet) is applied. The nut inside the Tensioning Bridge is backed-off two turns and the Bolt Tensioning Kit removed.

See FIG. 3.3.1

During the de-tensioning stage the Hydraulic Head should be backed off from the Tensioning Bridge by quarter of a turn before pressurisation to avoid locking up as the bolt retracts to its original length.



4.2.2 Remove the Nuts from the Bolt and remove the Bolt from the flange.

NOTE: To preserve coupling balance, when dismantling be sure to re-assemble the Bolt, Sleeve and Nuts associated with each bolt hole as a group.

PROCEDURE STEPS 4.2.1 to 4.2.2 ARE REPEATED FOR EACH BOLT IN THE FLANGE

**PILGRIM RADIAL FIT BOLTS
WITH EXTERNAL THREAD**
SECTION 5 HYDRAULIC PUMP AND HARNESS
5.1 INTRODUCTION

5.1.1 The Hydraulic Pump and Harness assemblies, when supplied, are complete and ready for use. Final connections between Pump and Hydraulic Head are made by simple quick release nipples and couplings.

Maximum Safe Working Pressure of flexible hose (4-ply -Blue - Type 5/4), quick release nipples and couplings is 1500 Bar (21,750 psi).

NOTE: It is important for efficient operation of the PILGRIM Radial Fit Bolts that the correct grade of hydraulic oil is used.

The Hydraulic Pump should be filled with a premium grade hydraulic oil having an ISO Viscosity grade number ISO VG 32 having Kinematic Viscosity limits at 40 deg.C of 28.8 cSt minimum to 35.2 cSt maximum.

Typical grades are: Shell Tellus V25
Esso Nuto HP32

5.2 SETTING AND TENSIONING BOLTS

5.2.1 The pressurisation of the Hydraulic Heads can be achieved in two alternative ways:-

- 1) Shown in FIG. 5.1.2. This illustrates the pump and harness set-up for the setting and tensioning of a single Radial Fit Bolt.
- 2) Shown in FIG. 5.1.3. This illustrates the pump and harness set-up for the setting and tensioning of two Radial Fit Bolts simultaneously.

NOTE: (2) can only be used when 2 Hydraulic Heads and a connector hose is supplied.

5.3 RELEASING BOLTS

5.3.1 During the dismantling of the Bolts, each bolt is released individually. This is illustrated in FIG. 5.3.1 and FIG. 5.3.2 for both oil injection releasing and for Hydraulic Head releasing.

DO NOT ATTEMPT TO RELEASE TWO BOLTS SIMULTANEOUSLY

5.4 SAFETY NOTES

5.4.1 It is important that all personnel working with the hydraulic equipment should adhere to the Safety Notes covered in Section 7.

Under no circumstances must a quick release nipple be pressurised when it is disconnected.



PILGRIM RADIAL FIT BOLTS
WITH EXTERNAL THREAD

SECTION 5 HYDRAULIC PUMP AND HARNESS (cont'd)

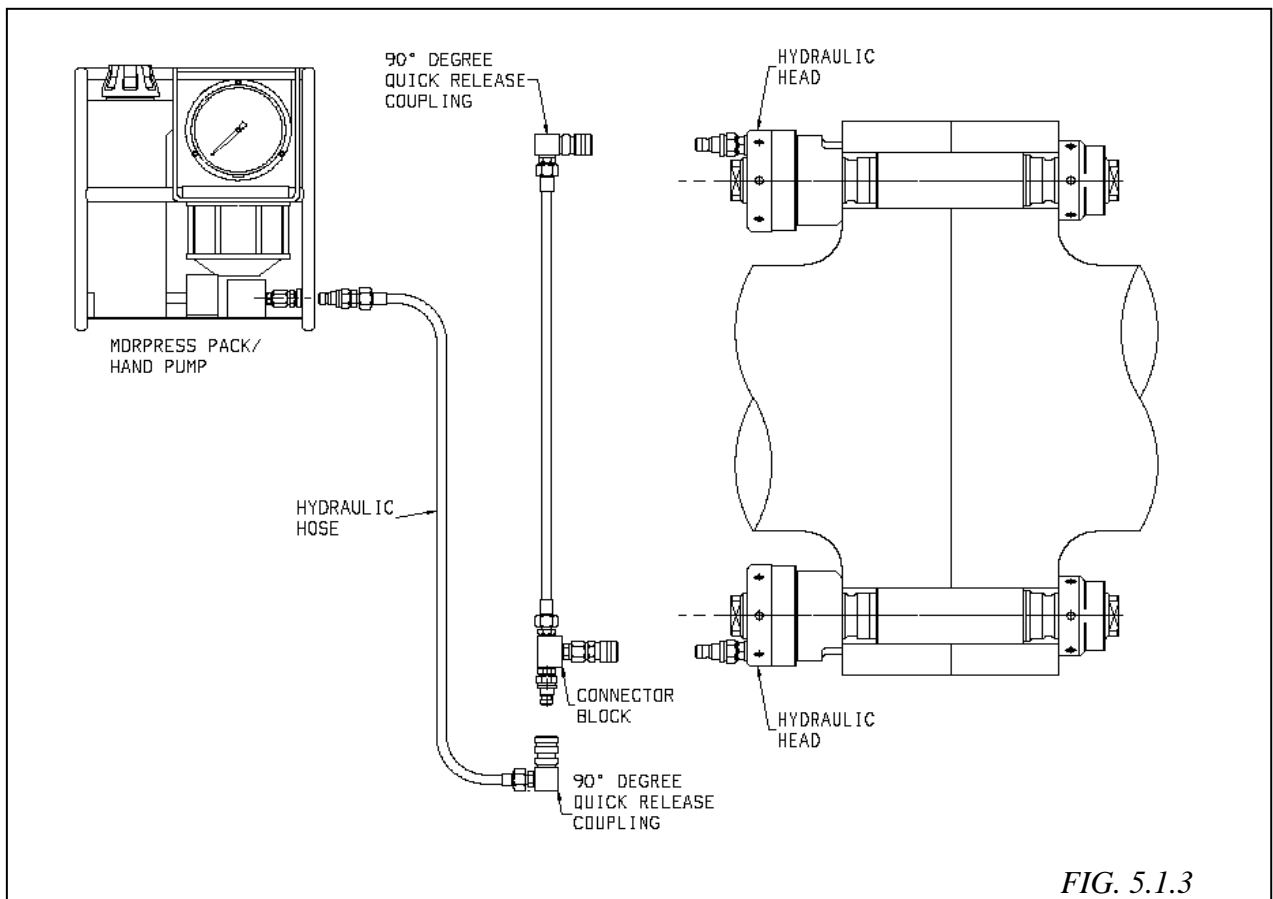
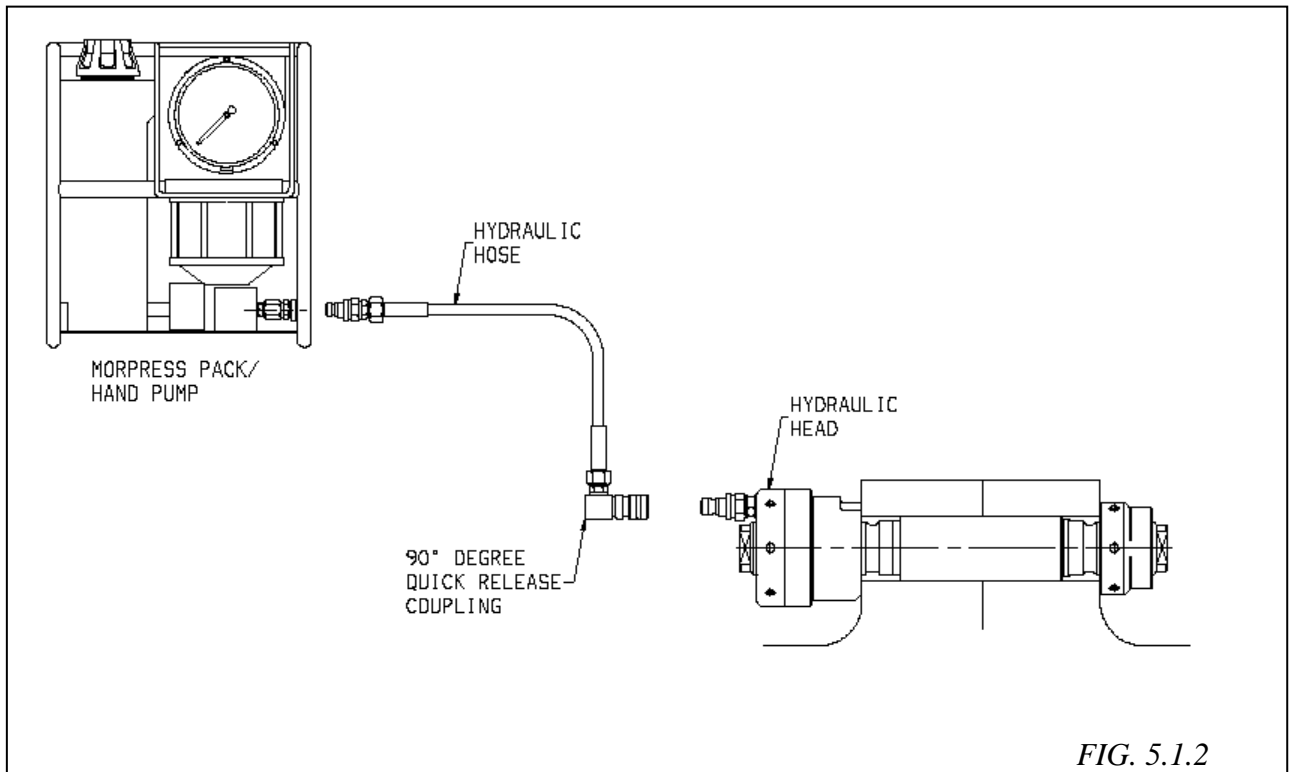

PILGRIM RADIAL FIT BOLTS
WITH EXTERNAL THREAD

SECTION 5 HYDRAULIC PUMP AND HARNESS (cont'd)

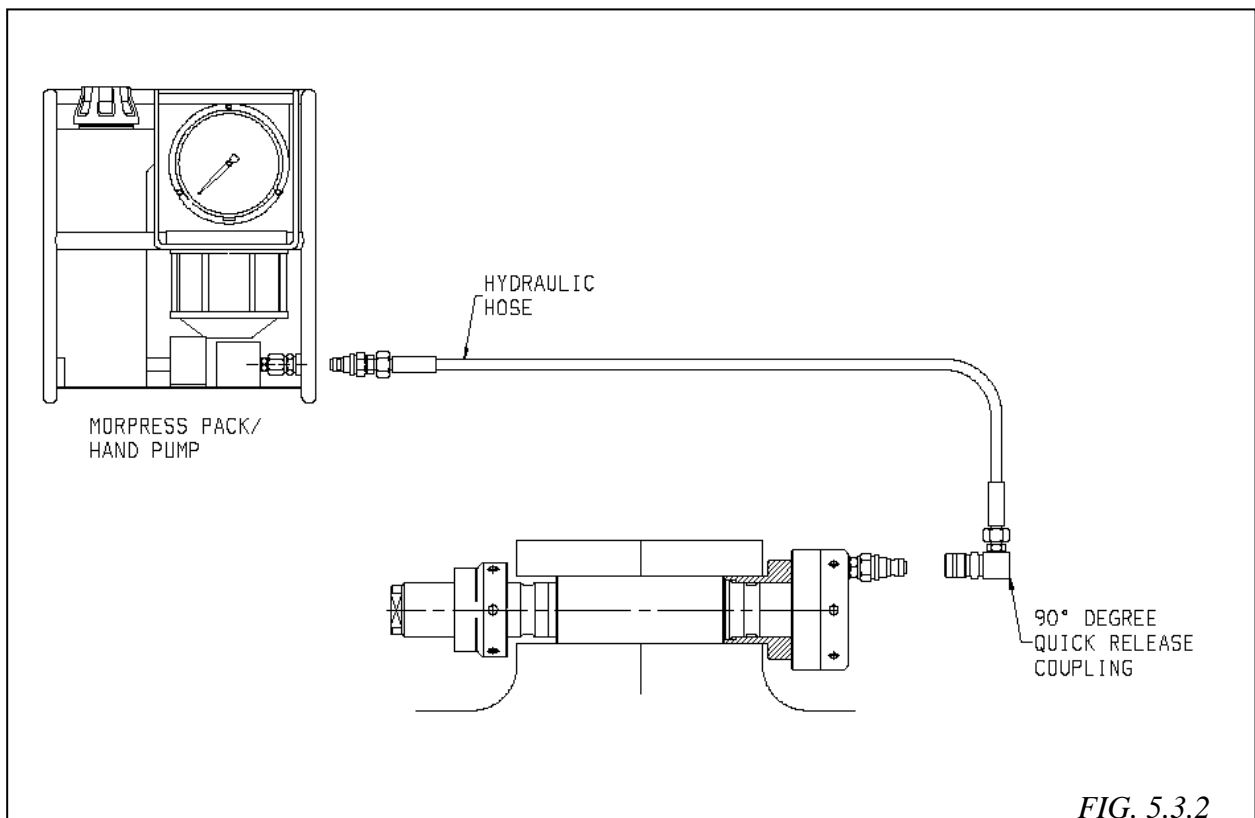
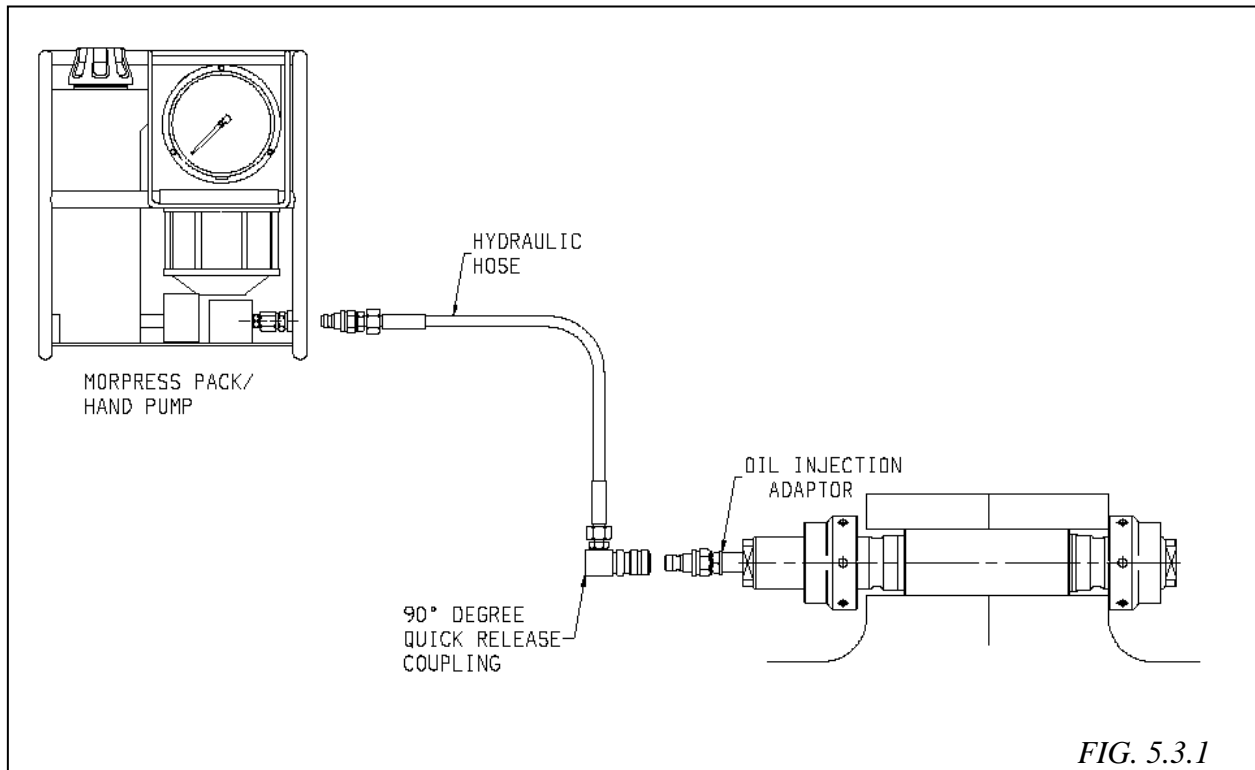

**PILGRIM RADIAL FIT BOLTS
WITH EXTERNAL THREAD****SECTION 6 RECOGNISING FAULTS AND PARTS REPLACEMENT****6.1 FAULT: Failure to build-up pressure required**

- 6.1.1. Check that pump oil reservoir is full.
- 6.1.2 Check air supply if air operated pump is being used.
- 6.1.3 Check all connections visually for leaking oil. Tighten any joint thought to be suspect.
- 6.1.4 Weeping at the conical joints (used on the Air Operated Pumps) evidenced by visual presence of oil, are sealed by increasing slightly the tightness of the adaptors..

CAUTION:

Do not overtighten the adaptors. It is sufficient to tighten a little at a time until the joint no longer leaks. If the leak persists, the adaptor should be replaced.

- 6.1.5 If oil emerges from around the Load Ring in the Hydraulic Head, the nitrile seal requires attention (See 6.6).
- 6.1.6 If oil leaks from around the quick release nipples on the Hydraulic Head or Hydraulic Hoses, the bonded (Dowty) seals should be replaced.
DO NOT RE-USE THESE SEALS.

6.2 FAULT: Failure of gauge to register pressure

- 6.2.1 When the pump initially begins to deliver oil to the Hydraulic Head, it does so against no resistance, other than a very small amount due to the friction of the circuit, pipes, etc. The pump will therefore reciprocate rapidly until the pressure build-up is sufficient to slow down the pumping action, at which point the pressure should begin to register on the gauge and increase steadily until the operating pressure is reached.
- 6.2.2 If the pumping action slows down, with no pressure showing on the gauge, the pump must be stopped immediately and the release valve opened to vent any pressure back to the oil supply tank.
- 6.2.3 Close the release valve and remove the gauge.
- 6.2.4 Start the pump, if oil exudes from the top of the gauge connection pipe, the gauge is faulty and must be renewed.

IT IS IMPORTANT TO DO THIS. THE WHOLE OPERATION OF INSTALLING A RADIAL FIT BOLT DEPENDS UPON THE CORRECT STRETCHING FORCE BEING APPLIED AND THE PRESSURE GAUGE IS THE ONLY MEANS OF MEASURING THIS FORCE.

**PILGRIM RADIAL FIT BOLTS
WITH EXTERNAL THREAD****SECTION 6 RECOGNISING FAULTS AND PARTS REPLACEMENT**

(cont'd)

6.3 FAULT: Pump Failure

- 6.3.1 Should the pump fail to operate it should not be tampered with; it must be returned to store for replacement/refurbishment.

6.4 FAULT: Difficulty with Bolt Assembly**WARNING:**

UNDER NO CIRCUMSTANCES MUST THE BOLTS BE FORCED INTO HOLES BY USING HAMMER BLOWS. THIS PRACTICE WILL RESULT IN DAMAGE TO THE BOLT AND THE FLANGE HOLE SURFACE.

- 6.4.1 Ensure that the machined parts (e.g. coupling flanges) are correctly aligned and that the bore is a continuous parallel diameter throughout the flanges.

- 6.4.2 If the Bolt will not enter the flange hole:-

- 6.4.3 Check that the Bolt and the hole markings are the same, to ensure that the correct Bolt is being fitted in its hole.

- 6.4.4 Re-check the flange holes and compare with the previously recorded values. Ensure that the edges of the holes are free from burrs.

- 6.4.5 Check the flange hole diameter and the sleeve diameter as follows:-

- i) Carefully measure the hole diameter along its full length. Measure two diameters at 90 deg. apart at each position, check for any out of roundness or parallelism.

If the hole is smaller than that measured and recorded in Section 2.2, the records should be revised with the new measurement. The sleeve must then be re-machined to the new hole measurement minus the clearance allowance stated in the Data Sheet.

It is important that the flange hole diameters must never be smaller than the machine manufacturer's original nominal diameter.

- ii) If, when measured, the hole diameter is correct with that recorded in Section 2.2 carry onto (iii) below.

- iii) Remove sleeve from Bolt and carefully measure the outside diameter along its full length. Measure two diameters at 90 deg. apart at each position. Check for any out of roundness.

If the sleeve is larger than the measured hole minus the clearance allowance specified in Data Sheet, re-machine the sleeve outside diameter using taper mandrel (see 6.6).

**PILGRIM RADIAL FIT BOLTS
WITH EXTERNAL THREAD****SECTION 6 RECOGNISING FAULTS AND PARTS REPLACEMENT**

(cont'd)

6.4 (cont'd)

6.4.6 If the Bolt enters the flange hole but has excessive clearance then:-

6.4.7 Check that the Bolt and hole markings are the same, to ensure that the correct Bolt is being fitted in its hole.

6.4.8 Check the flange bolt hole diameter and sleeve diameter as in 6.4.5 (i) and (ii). Check that the hole diameters are as previously recorded in Section 2.2. If the sleeve outside diameter is less than required, new sleeves of the correct diameter must be fitted.

DO NOT fit undersize Sleeves.**6.5 FAULT: Difficulty with Bolt Removal using Oil Injection Method**

6.5.1 If oil leaks from either end of Sleeve when attempting to release Sleeve as stated in Section 4.1.5, check that correct grade of hydraulic oil is being used - See Section 5.1.1.

If the correct grade of oil is being used and oil leaks occur or Sleeves fail to release at specified pressures, the alternative method recommended in Section 4.1.4 to 4.1.7 should be used.

6.6 PARTS REPLACEMENT6.6.1 **Hydraulic Head Seal replacement** - proceed as follows:-6.6.2 **NOTE:** It is important that spare nitrile seals are not removed from their packing until required. They should be stored at a temperature between 10 deg.C and 40 deg. C in an ozone free environment. Spare seals, when unpacked, must not be exposed for long periods to fluorescent light. In the event of seal failure the following procedure should be observed.

6.6.3 With the Hydraulic Head removed from the Bolt, apply low hydraulic pressure to expel Load Ring and Seal from the body. See Bolt Tensioning Kit Assembly Drawing in Data Sheet for identification of parts.

6.6.5 Remove old seal and discard. Thoroughly clean the annular chamber in the Body and the Load Ring.

**PILGRIM RADIAL FIT BOLTS
WITH EXTERNAL THREAD**

SECTION 6 RECOGNISING FAULTS AND PARTS REPLACEMENT

(cont'd)

6.6 PARTS REPLACEMENT - Hydraulic Head Seal (cont'd)

6.6.5 In general there are two types of seals used in the Hydraulic Head.

- 1) A loose low profile seal which sits on top of the Load Ring.
- 2) A captive inner and outer seal which fit into grooves in the side of the Load Ring

6.6.6 Re-assembly of Hydraulic Head and Seal. Apply a thin coating of grease to new seals and the chamber during re-assembly.

- 1) With low profile seal. Carefully insert the Seal with its lips pointing into the chamber. Insert the Load Ring, with recessed face towards Seal and carefully push into Body chamber
- 2) With Inner and Outer Seal. Mount the inner and outer seals onto the Load Ring. Insert the Load Ring with the seals facing the body chamber

Apply even pressure all round to ensure that Load Ring enters squarely to avoid jamming. Press the Load Ring in until fully engaged. (This is applicable to 1 & 2 above).

6.7 **MACHINING TAPERED SLEEVE**

6.7.1 If it is found necessary to re-machine the Sleeve outside diameter or if the Sleeves have been supplied oversize for finishing to suit individual hole sizes, the Sleeves must be fitted onto a mandrel which has a taper corresponding to Bolt taper to avoid permanent distortion of the Sleeve during this operation.

6.7.2 A tapered mandrel supplied by **Pilgrim** International Ltd should be used to ensure that the necessary accuracy is achieved.

6.7.3 Full details of hole preparation and Tapered Sleeve machining are given in Section 1.

6.8 **ORDERING SPARE PARTS**

When ordering any spare parts for Radial Fit Bolts, Clamp Bolts or for the Hydraulic Tensioning Equipment, quote the identification numbers etched on the parts. Also quote the Serial numbers and our company's Order reference which appear on the Data Sheet provided with the Manual.

**PILGRIM RADIAL FIT BOLTS
WITH EXTERNAL THREAD**

SECTION 7 SAFETY NOTES

- 7.1 High pressure hydraulic equipment can be dangerous if misused. Keep away from oil leakages at high pressure. Jets of liquid escaping from high pressure equipment have sufficient power to penetrate the skin, which will often cause blood poisoning. In the case of such an accident, **HOWEVER SUPERFICIAL, IMMEDIATE** medical attention **MUST** be sought.
- 7.2 Operation of this equipment must not be undertaken by lone workers. There must be no lone workers operating outside normal working hours.
- 7.3 Eye goggles must be worn when operating this equipment.
- 7.4 Gloves and suitable footwear must be worn when operating this equipment.
- 7.5 Hydraulic oils can produce skin complaints, therefore the following precautions must be taken:-
- 7.5.1 Many mineral oils are carcinogenic on prolonged contact with skin. They should therefore be washed off the skin as soon as possible after contamination.
- Barrier creams are some help in reducing skin contamination, but do not place undue reliance on them.
- 7.5.2 Change out of protective clothing or items of normal clothing that have become contaminated with oil. NEVER keep oily rags in overall pockets.
- 7.5.3 Avoid inhaling oil mist into the lungs.
- 7.6 **EATING, DRINKING AND SMOKING** are forbidden in the working area.

**PILGRIM RADIAL FIT BOLTS
WITH EXTERNAL THREAD**

SECTION 7 SAFETY NOTES (cont'd)

- 7.7 Certain basic rules for lifting and handling apply which are well known but which will be reiterated.
- 7.7.1 NEVER stand or put fingers under a slung load
- 7.7.2 ALWAYS use properly rated lifting equipment, slings, shackles, etc.
- 7.7.3 NEVER exceed ratings of slings, hoists or other lifting gear.
- 7.7.4 ALWAYS STOP, look and listen if anything strikes you as unusual.
- 7.8. **WASTE DISPOSAL:**
- 7.8.1 The legal regulations covering the disposal of liquid and solid waste must be adhered to by all personnel.
- 7.8.2 Liquid spillages must be collected immediately in an absorbent material held ready for the purpose. Provision must be made for the safe disposal of used absorbent.
- 7.8.3 Contaminated absorbent, particularly that with oil, must be stored only in metal bins with lids whilst awaiting collection.
- 7.9 Under NO circumstances must oxygen be used in the equipment covered by this Manual. Air at a pressure of 120 lbs. per sq. inch (8.2 Bar) maximum is the usual method of operating the MORPRESS Pack; however Nitrogen, Carbon Dioxide, Helium or any other inert gas may be utilised if air is not available.
- 7.10 **HIGH PRESSURE PIPEWORK:**
- 7.10.1 Steel piping should not be bent to less than six times the pipe outside diameter. No kinked bends must ever be used.
- 7.10.2 Flexible hoses, other than those supplied by **Pilgrim** International Ltd must never be utilised without the prior approval of **Pilgrim** International Ltd.
DO NOT bend Type 5/4 Blue flexible hoses to less than 150mm (6") radius.
- 7.10.3 Tubing should be checked periodically for accidental (external) damage.

**PILGRIM RADIAL FIT BOLTS
WITH EXTERNAL THREAD**

SECTION 7 SAFETY NOTES (cont'd)

- 7.10.4 No heating of the tubing must be allowed, e.g. for the attachment of clamps or shields by brazing, or to facilitate bending.
- 7.11 Modification of the equipment covered by this Manual should never be carried out by the customer, without consultation with the supplier, and without written approval of the modification(s) proposed.
- 7.12 **FIRE PROCEDURE:**
- 7.12.1 Fire may lead to leakage from or failure of, equipment such as that covered by this Manual. Whilst the hydraulic mineral oils used in this product are not inflammable under normal conditions: when leakage occurs it can atomise, or when heated it can vaporise, and in both circumstances become highly inflammable.
- 7.12.2 In these forms, therefore, a fire can be fed and may lead to it becoming of much greater intensity; in these circumstances therefore the following precautions should be taken:-
- a) If possible the hydraulic pressure should be relieved back to tank
 - b) The air pressure should be turned off and vented
 - c) Further, after the fire, any equipment that has been involved must be replaced, since invisible damage may have been caused to the metallurgical structure of the components.
- 7.13 Use only new or clean hydraulic oils, when replenishing the MORPRESS Pack tank.